

Wiring Centre Series

Model: UH8-RF Mini

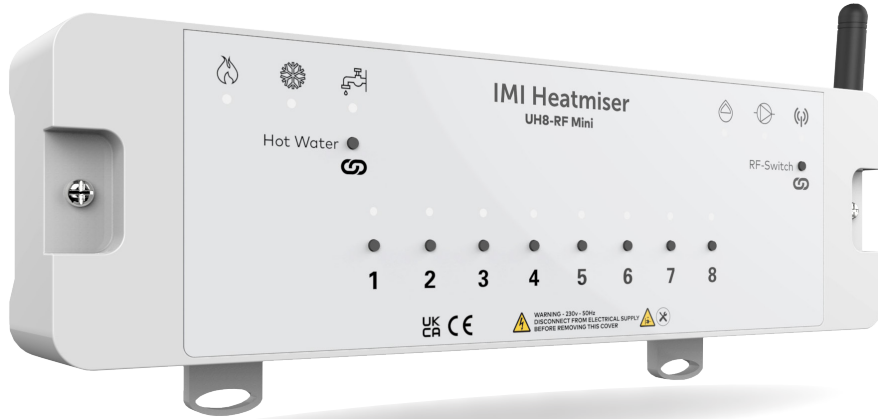

RF-Switch Compatible	Y
Boost Compatible	Y
Slimline-RF Compatible	Y
neoAir V1,V2,V3 & V4 Compatible	Y
Number of heating zones	8
Number of Hot Water Zones	1
LED Indication	Y
DIN Rail Mounting	Y
Supply	230v AC 50Hz 1 Phase
Relay Load Max	3 Amp Resistive
Total Load Max	5 Amp Resistive
IP Protection	IP20
Installed Dimensions (L,H,D)	300 x 90 x 50mm
Weight	1215g

Wiring Diagram UH8-RF

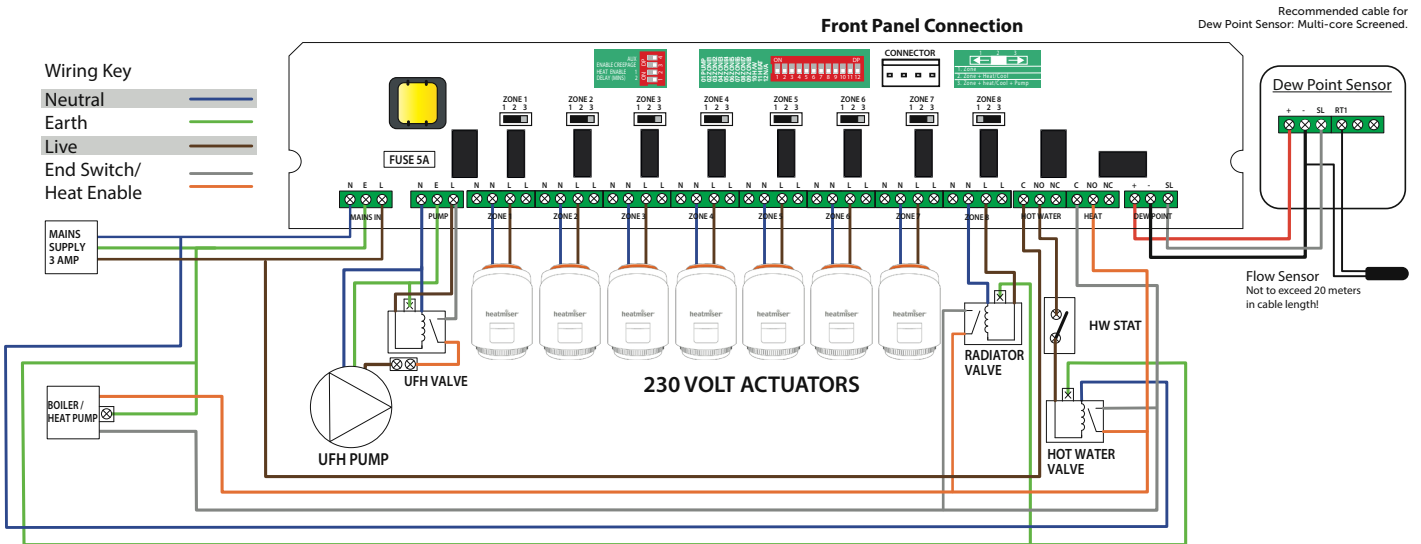

Product Dimensions (mm)

