



neoStat PRO

Smart Thermostat



Proven quality...

heatmiser

...in a new look

IMI Heatmiser

Model: neo Stat PRO





Table of Contents

Product Image	1	Optional Settings	17-18
Table of Contents	2	Cooling and Dew Point	19
What is a Programmable Room Thermostat?	3-4	Re-calibrating the Thermostat	20
Installation Procedure	5-6	Error Codes	20
Set Up & Pairing	7	Remote Probe Connections	21
What is a Mesh Network?	8	Wiring Diagrams	22-25
Approach Sensor	8	Statement of Compliance	26
LCD Display	9-10		
Display Options	11		
Temperature Display	12		
Comfort Levels Explained	13		
Temperature Control	14		
Frost Mode	15		
Holiday	16		
Unlocking the neoStat PRO	16		
Factory Reset	16		

What is a Programmable Room Thermostat?*

A programmable room thermostat is both a programmer and a room thermostat.

A programmer allows you to set "On" and "Off" periods to suit your own lifestyle.

A room thermostat works by sensing the air temperature, switching on the heating when the air temperature falls below the thermostat setting, and switching it off once this set temperature has been reached.

So a programmable room thermostat lets you choose what times you want the heating to be on, and what temperature it should reach while it is on. It will allow you to select different temperatures in your home at different times of the day (and days of the week) to meet your particular needs and preferences.

Setting a programmable room thermostat to a higher temperature will not make the room heat up any faster. How quickly the room heats up depends on the design and size of the heating system.

Similarly reducing the temperature setting does not affect how quickly the room cools down. Setting a programmable room thermostat to a lower temperature will result in the room being controlled at a lower temperature, and saves energy.

The way to set and use your programmable room thermostat is to find the lowest temperature settings that you are comfortable with at the different times you have chosen, and then leave it alone to do its job.

The best way to do this is to set the room thermostat to a low temperature – say 18°C, and then turn it up by 1°C each day until you are comfortable with the temperature. You won't have to adjust the thermostat further. Any adjustment above this setting will waste energy and cost you more money.

You are able to temporarily adjust the heating program by overriding the set temperature. See page 14 for more details.

Programmable room thermostats need a free flow of air to sense the temperature, so they must not be covered by curtains or blocked by furniture. Nearby electric fires, televisions, wall or table lamps may also prevent the thermostat from working properly.

***Note; this unit is only programmable when paired to a neoHub.**



Installation Procedure



Do

Mount the thermostat at eye level.
Read the instructions fully so you get the best from our product.



Don't

Do not install near to a direct heat source as this will affect functionality.
Do not push hard on the LED panel as this may cause irreparable damage.

The neoStat PRO is designed to be flush mounted and requires a back box of 35mm (minimum depth) to be sunk into the wall prior to installation.

Step 1

Using a small screwdriver, slightly loosen the screw from the bottom face of the thermostat. Then carefully separate the front half from the back plate.

Step 2

Place the thermostat front panel somewhere safe. Terminate the thermostat as shown in the diagrams on pages 22-25 of this booklet.

Step 3

Screw the thermostat back plate securely into the back box.

Step 4

Clip the front of the thermostat onto the back plate, securing it in place with the retaining screw.

1



2



3

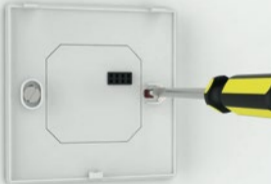

4





Set Up & Pairing



Pairing the neoHub

To pair the neoHub with the neoApp, follow these steps.

- Connect the neoHub to your router with the Ethernet cable provided.
- Connect the power supply to the neoHub.
- The router will automatically assign an IP address to the neoHub, and the Link LED will turn red once it's connected to your network.
- When connected to the Heatmiser cloud server, the Link LED will turn GREEN.
- Connect your smartphone or tablet device to the same WiFi network as your router.
- Download the FREE Heatmiser neoApp from the Apple App Store or Google Play Store and register an account.
- Once you have registered your account, press Sign In, then press Add Location.
- Press the connect button on the neoHub to add the location to your account.
- When successfully connected, enter a title for the location (e.g. Home).

Pairing the neoStat Pro

The next step is to join the neoStat PRO to the neoHub.

To add a neoStat PRO, follow these steps;

- In the app, select ADD NEOSTAT, enter a preset or custom title, then press NEXT.
- You now have two minutes to join the neoStat Pro to the neoHub.
- On the neoStat PRO, hold both tick and up keys until the mesh symbol appears flashing on the display.....

- When the neoStat PRO successfully connects to the neoHub the MESH symbol will be permanently displayed and a confirmation will show on the app.
- In the app, press ADD ANOTHER for additional zones or press FINISH to complete setup.

**Please note, you only have to pair the hub to your account once.
To pair any additional neoStats, select ZONES, edit, then ADD ZONE.**



What is a Mesh Network

neoStats work using a mesh network, meaning neoStats have the ability to send & receive signals via other thermostats on the network. This signal is relayed from one thermostat to another until it reaches its destination. This communication method extends the communication range whilst offering increased network stability when compared with standard RF thermostats. The Mesh symbol is shown when the device is communicating with the neoHub, if the mesh symbol disappears this indicates connection to the neoHub has been lost.



Approach Sensor

The neoStat PRO uses proximity to detect when you are about to use the touch keys. As you approach the thermostat, the touch keys and backlight will light up. This can be useful if you need to adjust the set temp or timer in a dark room.

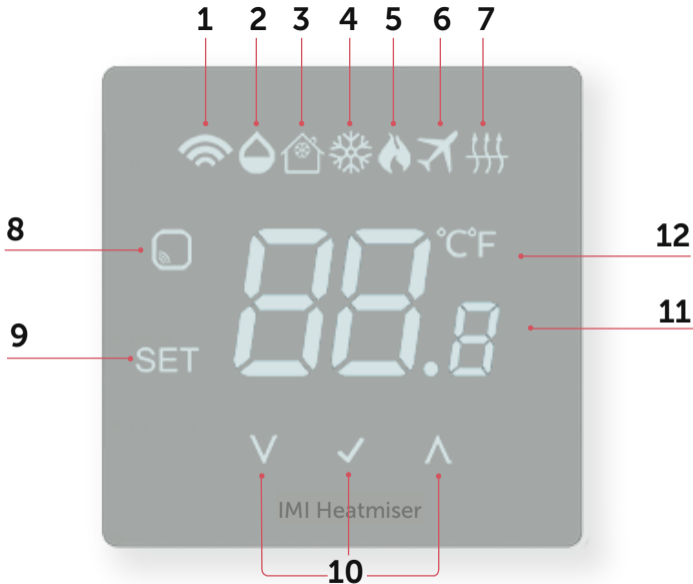

1. Mesh Symbol - Displayed when connected to the neoHub.
2. Dew Point - Shows when the floor has reached dew point temperature and shuts down cooling.
3. Frost Protection – Displayed when frost protection is enabled.
4. Snow Flake – indicates when cooling is active.
5. Flame Symbol – Displayed when the thermostat is calling for heat and flashes when optimum start is active.
6. Holiday – Displayed when the thermostat is in holiday/away mode.
7. Floor Limit Symbol – Displayed when the floor probe has reached the floor temperature limit configured in the setup menu.
8. Sensor Warning - Flashes on screen when the neoStat PRO has failed to receive a signal from a Wireless Sensor or Window/Door Switch.
9. Set - Displayed when changes are being made to the current set point.
10. Touch Keys - Change set temperature and enable frost protection.
11. Temperature – Displays the current sensor temperature.
12. Temperature Format - Degrees Celsius or Fahrenheit.



Display Options

The neoStat PRO gives you the option to have either an ambient temperature or blank display. When using the keypad, the display will show at full brightness then dim back or go blank after a few seconds of no interaction.

Blank (Default)



User Interaction



Dimmed level



To change these options:

- Hold down the tick key until you see either 01, 02 or 03 in the centre of the display.....
- Tap the Up/Down keys followed by tick to select the desired setting.....
- Display On, Brightness Level 1 (Medium) = 01
- Display On, Brightness Level 2 (Low) = 02
- Display Off = 03 (Default)





Temperature Display

The neoStat PRO can be configured for different sensor options such as built in air sensor, floor sensor or both.

Room/Floor Temperature



When the neoStat PRO is set to use both the air & the floor sensor, the room temperature will be displayed by default.

- To view the current floor temperature, press and hold the Down Arrow and Tick keys for 5 seconds, the floor temperature will then be displayed momentarily until reverting back to room temperature..... ✓✓



Comfort Levels Explained

neoApp Only

When paired with a neoHub, the neoStat PRO offers three programming modes: Weekday/Weekend (5/2 day), 7-Day, and 24-Hour. By default, it functions as a non-programmable thermostat.

When thermostats are connected to the mesh network, the program mode for the system is configured by using the neoApp.

Activated by the neoHub, the thermostat is pre-programmed with a set of comfort levels, but these can be changed easily. The default times and temperature settings are;

Heating defaults

07:00 - 21°C (Wake) 09:00 - 16°C (Leave) 16:00 - 21°C (Return) 22:00 - 16°C (Sleep)

Cooling defaults

07:00 - 23°C (Wake) 09:00 - 26°C (Leave) 16:00 - 23°C (Return) 22:00 - 26°C (Sleep)

If you only want to use 2 levels, you should program the unused levels to --:--

For Weekday/Weekend programming, the four comfort levels are the same for Mon-Fri, but can be different for Sat-Sun. For 7 Day programming, each day of the week can be set differently. In 24 hour mode all days are programmed with the same comfort levels.

To access and customise these comfort levels, please refer to the mobile app.



Temperature Control

- The Up / Down keys allow you to adjust the set temperature..... ^ v
- When you press either key, you will see the word SET and the desired temperature value. Use the Up / Down keys to adjust the SET value..... ^ v
- Press Tick to confirm settings and return to the main display..... ✓



Note: When used as a programmable thermostat, this new set temperature is maintained only until the next programmed comfort level. At this time, the thermostat will revert back to the programmed levels.



Frost Mode

- The frost icon will toggle ON/OFF each time Tick is pressed..... ✓
In this mode, the neoStat will display the frost icon and will only turn the heating ON should the room temperature drop below the set frost temperature (see page 17). If the heating is turned ON whilst in frost mode, the flame symbol will be displayed.
- To cancel the frost protect mode, press Tick again..... ✓





Frost Protection
Mode Enabled



In thermostat mode, the holiday function reduces the set temperature in your home to the frost protection temperature setting (see page 17).

The thermostat will maintain this temperature for the duration of the holiday and will then automatically return to the program mode on your return.

Unlocking the neoStat PRO

- To unlock the neoStat Pro press Tick once.....✓
The display will show "00" and you will need to enter the four digit pin number you set previously via the app.
- Use the Up / Down keys followed by ✓ to enter the first two digits.....
- Use the Up / Down keys followed by ✓ to enter the second two digits..
The display will unlock and return to the main screen.

Factory Reset

To reset the device to factory default settings;

- Hold down all three keys until every icon shows on the display as illustrated on page 9.....



Optional Settings (neoApp Only)

MANY OF THESE SETTINGS ARE INACCESSIBLE AND INACTIVE UNTIL THE THERMOSTAT IS PAIRED TO A NEOHUB SYSTEM.

Switching Differential: This function allows you to increase the switching differential of the thermostat. The default is 1°C which means that with a set temperature of 20°C, the thermostat will switch the heating on at 19°C and off at 20°C. With a 2°C differential, the heating will switch on at 18°C and off at 20°C.

Frost Protect Temperature: This is the temperature maintained when the thermostat is in Frost Mode. The range is 05 - 17°C. The default is 12°C and is suitable for most applications.

Output Delay: To prevent rapid switching, an output delay can be entered. This can be set from 00 - 15 minutes. The default is 00 which means there is no delay.

Temperature Up/Down Limit: This function allows you to limit the use of the up and down temperature arrow keys. This limit is also applicable when the thermostat is locked and so allows you to give others limited control over the heating system.

Sensor Selection: The neoStat PRO automatically detects and uses remote probe connections. Once connected, you may change sensor configuration via the neoApp to meet requirements. You can select between air temperature only, floor temperature, or both. When you enable both sensors, the floor sensor is used as a floor limiting sensor and is designed to prevent the floor from overheating.

Dew Point: In cooling mode the thermostat will use the air, floor and humidity sensors to calculate the dew point temperature. Once the floor approaches dew point, the thermostat will stop cooling.

Floor Temp Limit: This function is available when the thermostat is set to use air and floor sensing options . You can set a floor limiting temperature between 20-45°C (28°C is the default setting).

Note: This unit **MUST NOT** be used to control electric underfloor heating.

Cool Enable: Allows the thermostat to actively cool when the system is in cooling mode.

Optimum Start: Optimum start will delay the start up of the heating system to the latest possible moment to avoid unnecessary heating and ensure the building is warm at the programmed time. The thermostat uses the rate of change information to calculate how long the heating needs to raise the building temperature 1°C (with a rate of change of 20, the thermostat has calculated the heating needs 20 minutes to raise the building temperature 1°C) and starts the heating accordingly.

Rate of Change: Number of minutes for 1°C temperature rise. The default setting is 20 minutes and can change on a daily basis. This setting cannot be changed and is for information only.

Program Mode: Non-Programmable, Weekday/Weekend (5/2), 7 Day Programming or 24 Hour.

Weekday/ Weekend - allows you to program 4 comfort levels for the weekday and 4 different comfort levels for the weekend.

7 Day Program Mode - Each day has 4 comfort levels that can be programmed independently.

24 Hour Mode - All days are programmed the same and repeat continuously.

Temperature Format: This function allows you to select between °C and °F.



Cooling and Dew Point (neoApp Only)

When used with the neoHub and HC-Switch, this thermostat can be used for underfloor cooling. In this mode the neoStat PRO will show a snowflake icon when active. A floor sensor must be fitted in order to monitor the floor temperature, so that the thermostat can calculate the dew point cut off. This will help to prevent condensation from forming on a tiled floor.

Cooling Active



Reached Dew Point



Cooling Disabled



By default, cooling is disabled and is indicated by dashes on the display when the system is set to cooling mode. To enable cooling, enter the zone settings menu in the app.....





Re-calibrating the Thermostat

If you need to re-calibrate the thermostat, follow these steps.

- Press and hold the Up / Down keys for 10 seconds. The tick key will blink once.....
- Use the Up / Down keys to change the offset.....
- Tap the Tick button to store and return to the main display.....



To remove any previously stored offset, a complete factory reset is required.



Error Codes

When terminated for thermostat operation the screen will display an error code if a fault is detected.

E0 = The internal sensor has developed a fault.

E1 = The remote FLOOR probe has not been connected.

The remote FLOOR probe has not been wired correctly.

The remote FLOOR probe is faulty.

E2 = The remote AIR probe has not been connected.

The remote AIR probe has not been wired correctly.

The remote AIR probe is faulty.



Remote Probe Connections

The neoStat PRO allows for up to two probe connections, remote floor and remote air. This thermostat automatically detects and uses remote probe connections.

Probe Types



Remote Floor Sensor
NTC Thermistor 10K3A1



Remote Air Thimble Sensor
NTC Thermistor 10K3A1

Input Connections

- Floor Sensor, use RT1 and Negative terminals.....
 - Air Sensor, use RT2 and Negative terminals.....
- Also refer to the diagram on page 25.

RT1	-
RT2	-

Important! If a probe connection is incorrect and the device is not paired to a neohub, a factory reset is required after corrections, to amend any remote probe configuration.



Wiring Diagram - neoStat to Boiler S/L

TO CONNECT THE BOILER, REFER TO THE BOILER MANUFACTURER'S WIRING DIAGRAM.

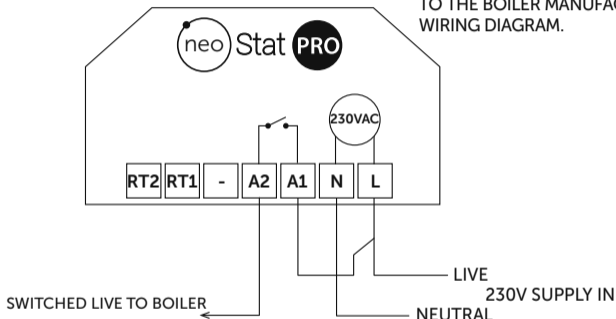

This product must only be installed by a qualified electrician and comply with local installation regulations.



Wiring Diagram - neoStat to Boiler Voltfree

TO CONNECT THE BOILER, REFER TO THE BOILER MANUFACTURER'S WIRING DIAGRAM.

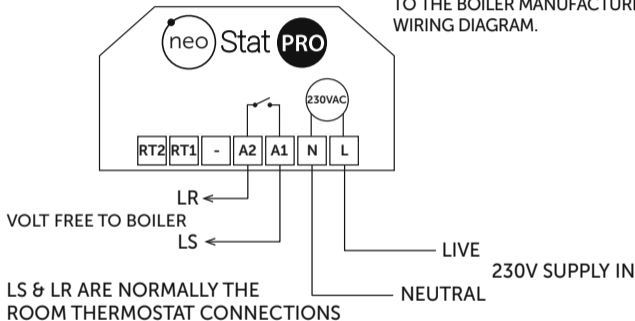

This product must only be installed by a qualified electrician and comply with local installation regulations.



Wiring Diagram - neoStat to Valve

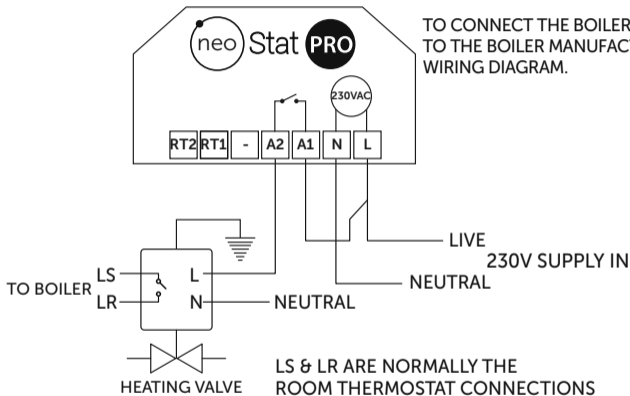

This product must only be installed by a qualified electrician and comply with local installation regulations.



Wiring Diagram

neoStat to UH8 and Optional Remote Probe Connections

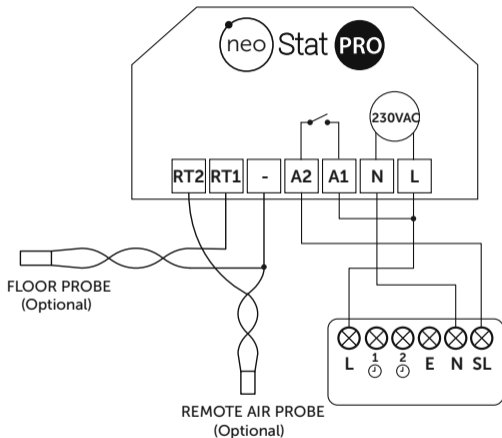

This product must only be installed by a qualified electrician and comply with local installation regulations.



Statement of Compliance

neoStat family

Scan for the required Statement of Compliance, including the security update support period.





Want More Information?

Call our support team on: +44 (0)1254 669090

Or view technical specifications directly on our website:
www.heatmiser.com



PDF



FAQ

IMI Heatmiser
Units 1-5 Hurstwood Court, Mercer Way
Shadsworth Business Park, Blackburn,
Lancashire, BB1 2QU, United Kingdom.

Hereby, Heatmiser UK Ltd. declares that the radio equipment type (designation of type of radio equipment) is in compliance with Directive 2014/53/EU.
RF Frequency: 2.4ghz 9.18dBm

Rev.1.4